

KOTEN: Fixpunkt: 1156.297 m.o.M.
 MFH A: 1147.59 m.o.M. = -8.735 m = OKFEG
 MFH B: 1146.41 m.o.M. = -9.965 m = OKFEG

Bauherr: _____
 Grundeigentümer: _____
 Architekt: _____

LEGENDE:
 Galeriefächern

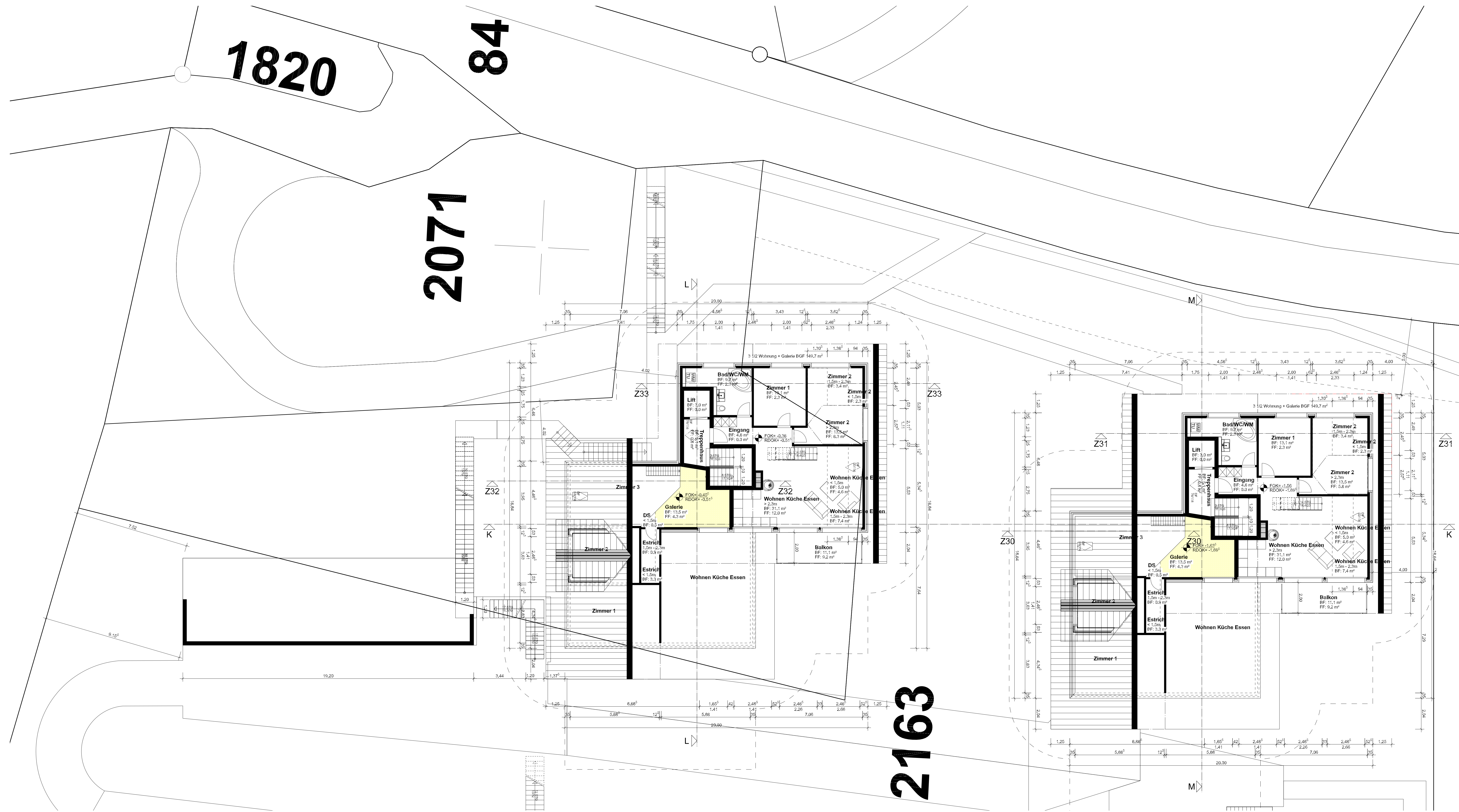
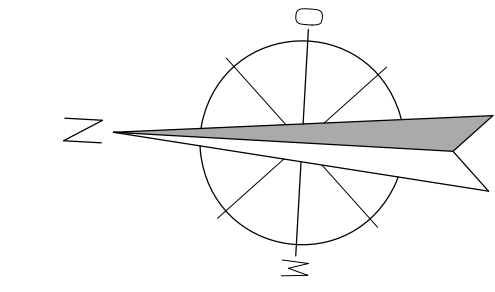

Geschosse Übersicht

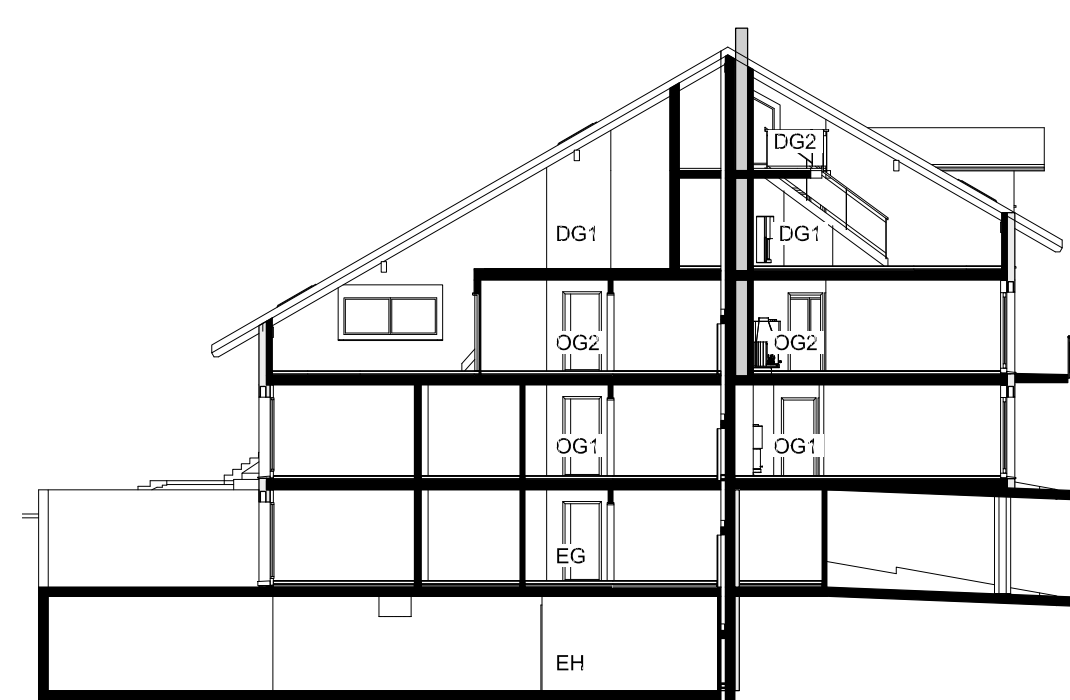

Schnitt Z32-Z33
 Mindesthöhe nach BauV Art.67

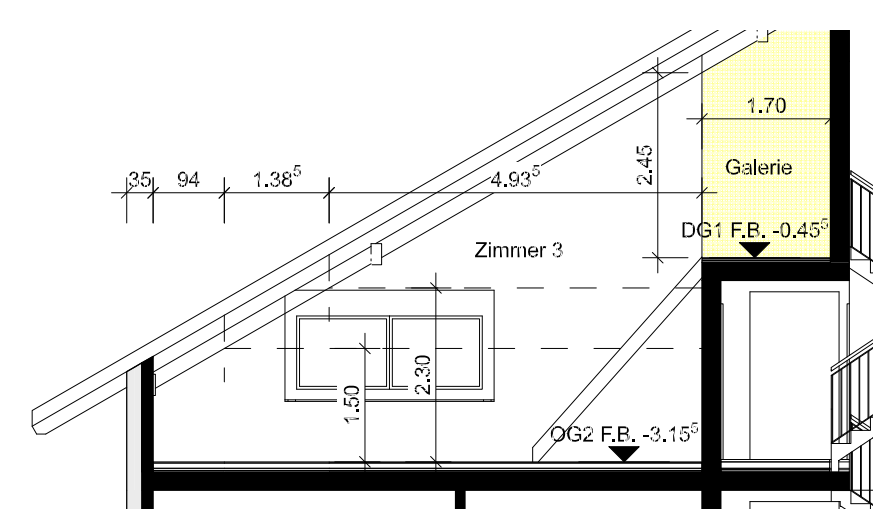

Schnitt Z33-Z30
 Mindesthöhe nach BauV Art.67

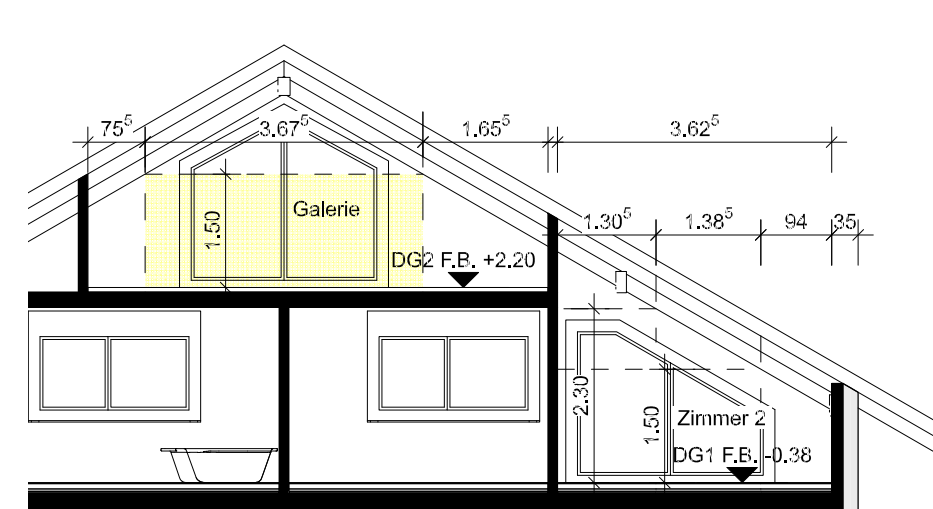

Schnitt Z30-Z30
 Mindesthöhe nach BauV Art.67

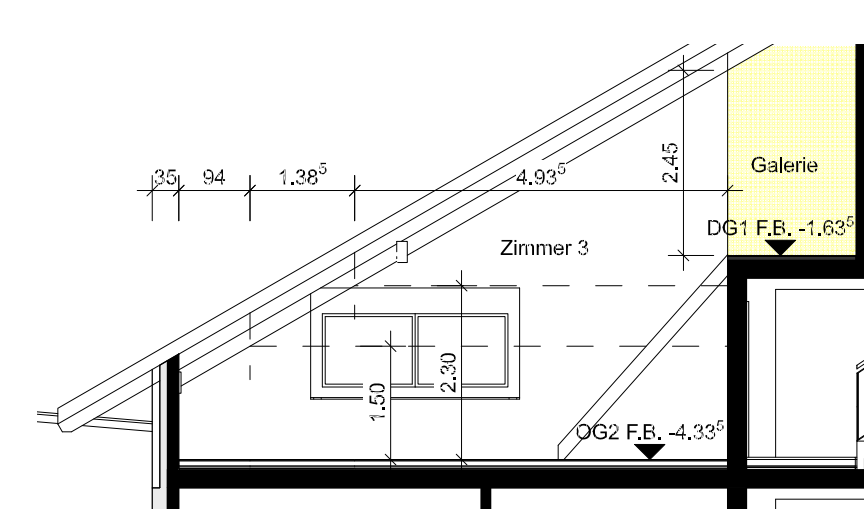

Schnitt Z31-Z31
 Mindesthöhe nach BauV Art.67

